

SPECIFICATIONS

The growing interest for **environmental protection and safety** is focussing more and more not only on treatment for domestic sewage or the like but also, particularly in recent years, on treatment systems for runoff from potentially polluted impermeable surfaces.

This includes water from car washes, which is characterised by the presence of **various types of pollutants** such as: suspended solids (sand and mud, gravel, grit, vegetable residues,...), detergents, oils and hydrocarbons. For this reason, the purification treatment of these effluents requires a series of phases that treat the pollutants in succession. Choice of the different types of treatment varies according to the final discharge. The inlet concentrations are : SS ≤ 400 mg/l ; Total Hydrocarbons ≤ 50 mg/l ; Total Surfactants ≤ 15 mg/l.

The first phase consists of a **grit separator** in which all the compounds of specific weight different to that of water are separated by gravity: the heavier materials (sand, mud, gravel,...) settle to the bottom of the tank while the lighter materials (oil, grease, foam,...) accumulate at the surface. The outlet pipe draws from halfway down the tank to prevent the separated material from being drawn-off.

The second phase is the **oil separation**. The residual oils and hydrocarbons are trapped by the coalescing filters, thus separating them from the effluent.

In the third phase, the effluent is subjected to intensive biological treatment, in which the particular strains of bacteria digest the dissolved organic substances (BOD5 and COD) and the detergents (Phosphorous). According to the final discharge concentrations requested by the local regulations, the third treatment phase consists of: an aerated trickle filter (DEPAUTO PF); an anaerobic trickle filter and an aerated trickle filter with sludge recirculation (DEPAUTO); an aerated trickle filter and a final quartzite and activated charcoal filter system (DEPAUTO T4) that permit to reuse the treated water for the pre-wash phase of the washing cycle. The blowers of the aerated trickle filters must remain in operation 24 hours a day.

USE

treatment of water from manual and automatic car wash areas

REFERENCE STANDARDS

Standard UNI EN 858-1 (oil separator), local standards for treatment of rainwater and surface runoff.

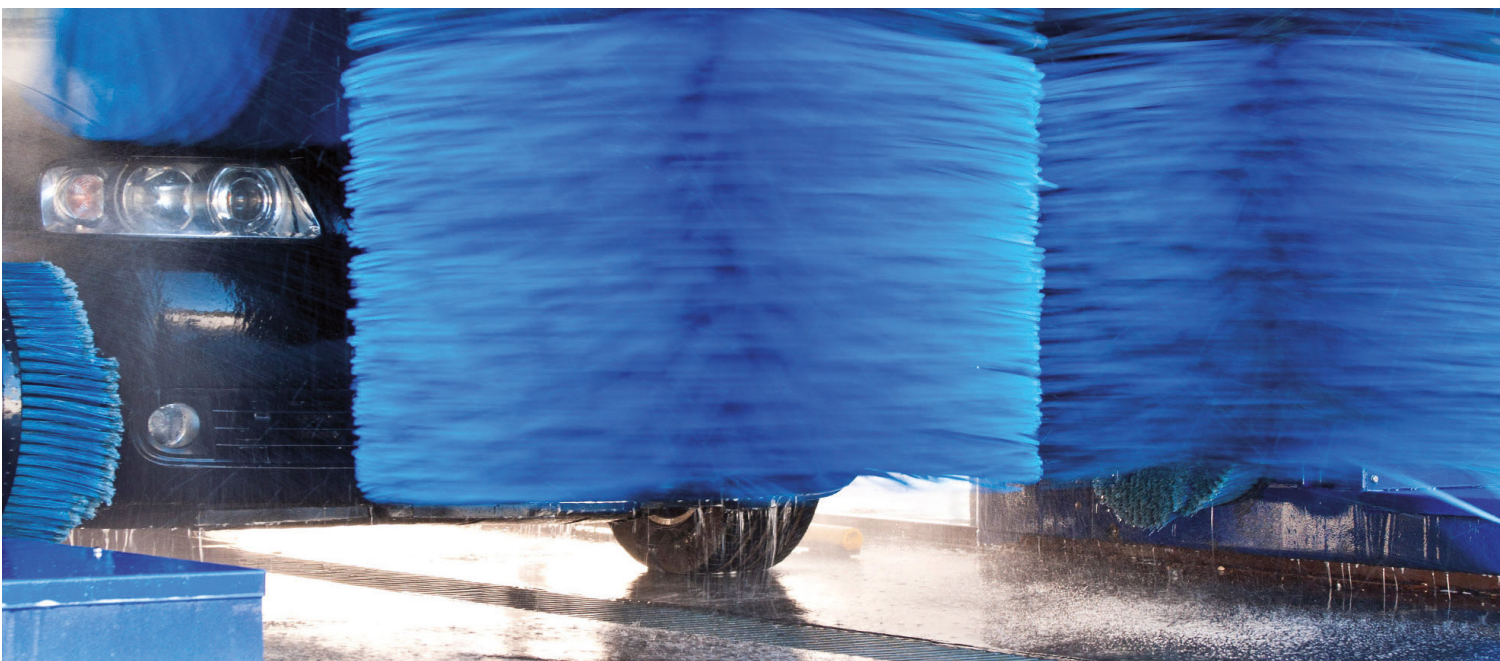

EXTERNAL TREATMENT SYSTEMS FOR CAR WASHES

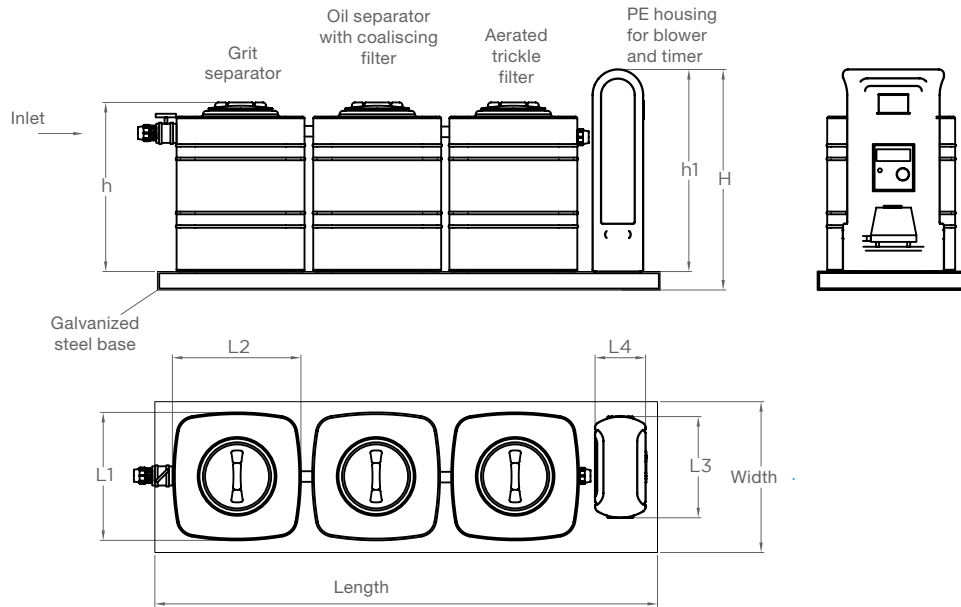

Item	Cars/day n°	Over all dimensions length x width x H mm	Grit separator/Oil separator/filter L1 x L2 x h mm	PE housing L3 x L4 x h1 mm	ØI - ØO mm	Total volume l	Blower W
DEPAUTOEST10	0-10	3400 x 1000 x 1300	760 x 760 x 980	300 x 600 x 1200	50-75	1350	31

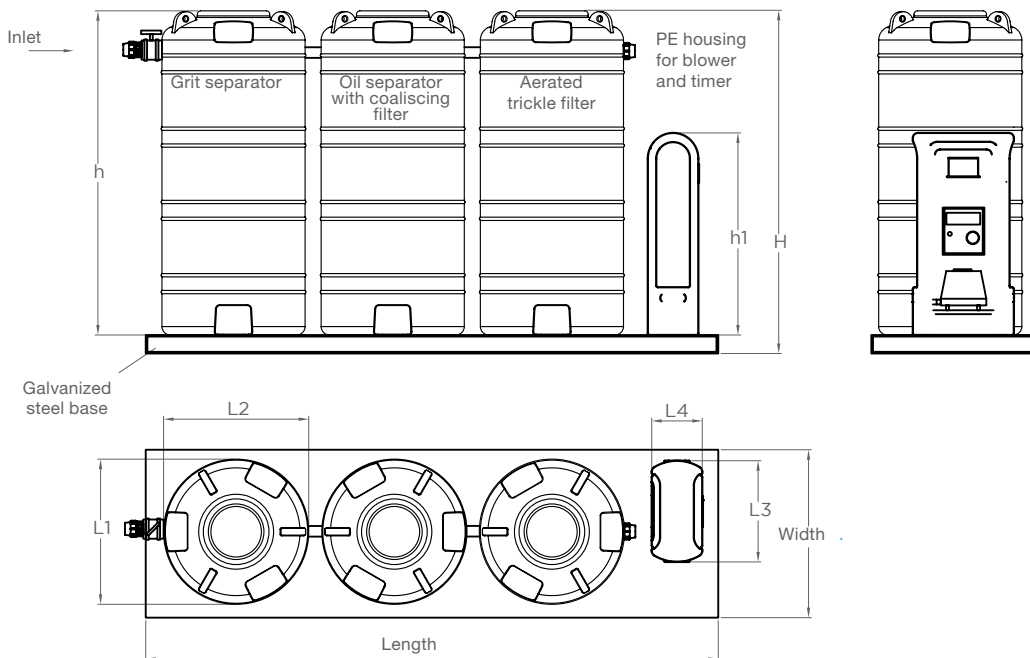

Item	Cars/day n°	Over all dimensions length x width x H mm	Grit separator/Oil separator/filter L1 x L2 x h mm	PE housing L3 x L4 x h1 mm	ØI - ØO mm	Total volume l	Blower W
DEPAUTOEST20	11-20	3400 x 1000 x 2003	850 x 850 x 1930	300 x 600 x 1200	50-75	2700	31