

LIFT STATIONS

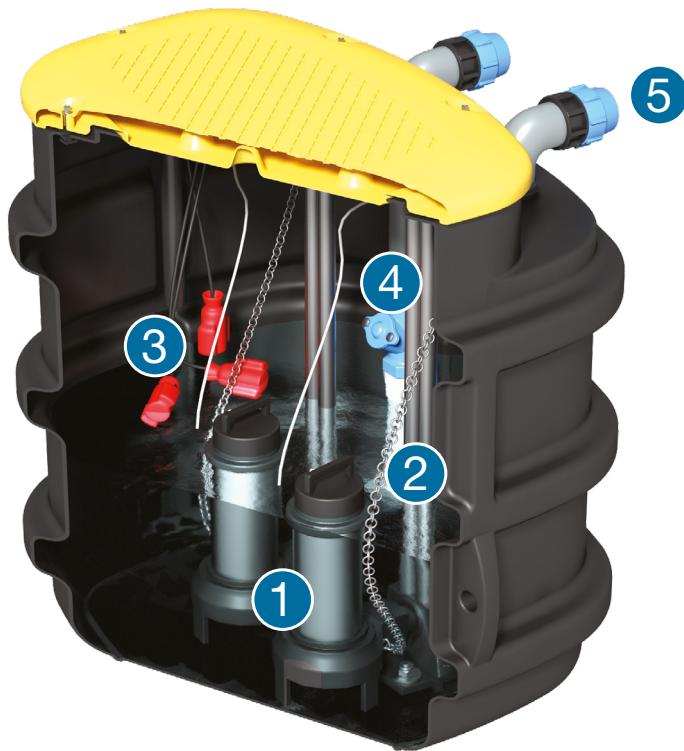

- 1 SUBMERSIBLE ELECTRIC PUMPS
- 2 STAINLESS STEEL DOWNPIPE AND QUICK-CONNECTION SYSTEM
- 3 COMMAND FLOATS
- 4 CAST IRON BALL CHECK-VALVE
- 5 OUTLET PIPES



SPECIFICATIONS

TECHNICAL CHARACTERISTICS

Sewage lift stations are systems that allow effluent to be lifted and transferred to stations located at higher levels (sewerage systems, treatment systems). They become necessary, for example, when the discharge level of a WC is lower than that of the treatment plant or sewerage pipes (cellars, underground premises, etc.) and when the hydraulic profile of the treatment system cannot work by gravity. The station consists of a linear polyethylene (LLDPE) storage tank of various sizes, with a submerged electric pump installed inside it. If the flow rates of waste water to be lifted are very high and/or variable and if the presence of a spare pump is necessary, dual pump models are provided. The pumps are connected to suitable electric panels so that, according to requirements, the start-up command can be either manual or automatic by means of start/stop float switches located inside the tank. Depending on need, the lift stations can be equipped with various types of pumps with different heads, flow rates and working pressures. For pumps possessing particular characteristics, contact the ROTOTEC technical office.

USE

to pump pre-treated and untreated waste water, rainwater, etc. to higher levels.

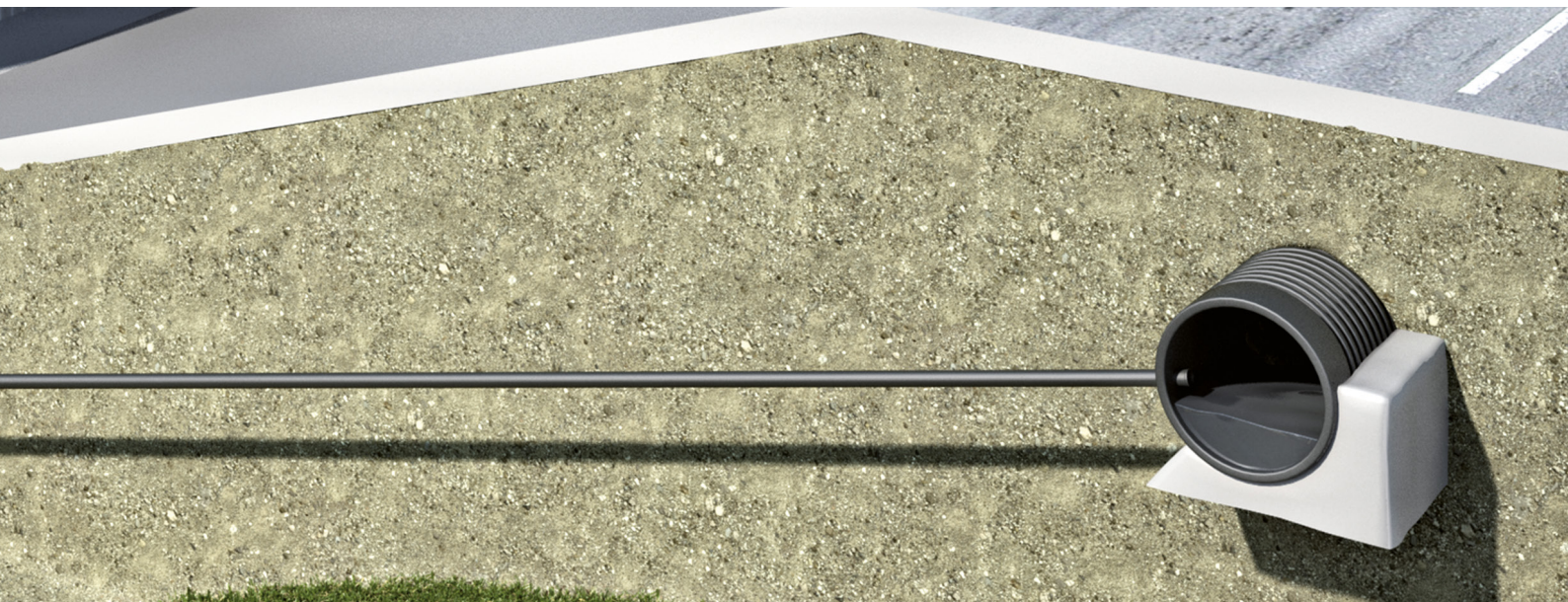

PICO SOL LIFT STATIONS

SMALL VOLUMES

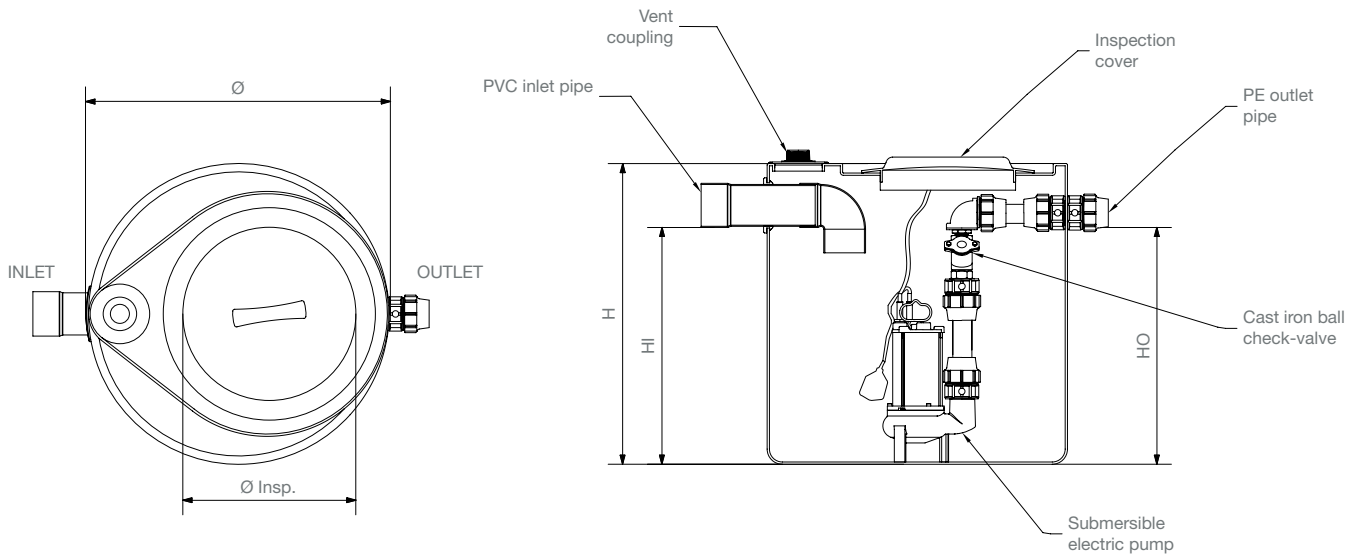

SINGLE PUMP

Item	Volume l	Ø mm	H mm	HI mm	HO mm	Ø I-O mm	Ø insp. mm	Pump	Impeller type	Kw	Flow rate l/min	Head m
SOL150	120	580	660	510	510	110-50	300	PNRG01	Vortex	0,3	10-140	6-1
SOL326	230	630	970	750	750	110-50	400	SM265	Vortex	0,55	0-300	8,5-1
SOL345	230	630	970	750	750	110-63	400	SM390	Vortex	0,75	0-500	10,5-1
SOL312	230	630	970	750	750	110-63	400	SM125	Grinder	1,18	0-110	30-3
SOL302	230	630	970	750	750	110-63	400	PMST2	Grinder	0,9	35-215	16-4
SOL526	305	790	790	625	625	110-50	400	SM265	Vortex	0,55	0-300	8,5-1
SOL545	305	790	790	625	625	110-63	400	SM390	Vortex	0,75	0-500	10,5-1
SOL563	305	790	790	625	625	110-63	400	SM635	2-channel	1,1	0-650	15-0
SOL512	305	790	790	625	625	110-63	400	SM125	Grinder	1,18	0-110	30-0
SOL502	305	790	790	625	625	110-63	400	PMST2	Grinder	0,9	35-215	16-4

Single and dual-pump lift stations, size 120 - 300 l

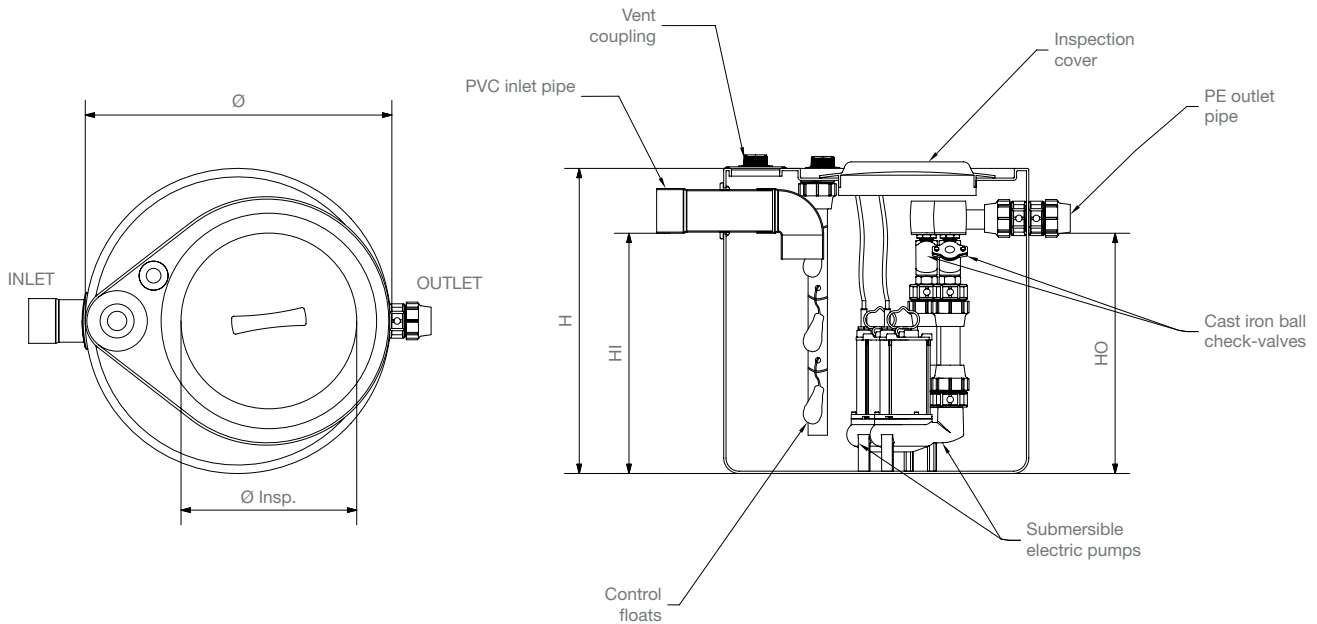

DUAL PUMP

Item	Volume l	Ø mm	H mm	HI mm	HO mm	Ø I-O mm	Ø insp. mm	Pump	Impeller type	Kw	Flow rate l/min	Head m
SOL526P2	305	790	790	625	625	110-63	400	SM265	Vortex	0,55	0-300	8,5-1
SOL545P2	305	790	790	625	625	110-63	400	SM390	Vortex	0,75	0-500	10,5-1
SOL563P2	305	790	790	625	625	110-63	400	SM635	2-channel	1,1	0-650	15-0
SOL512P2	305	790	790	625	625	110-63	400	SM125	Grinder	1,18	0-110	30-0
SOL502P2	305	790	790	625	625	110-63	400	PMST2	Grinder	0,9	35-215	16-4

PUMPS FOR LIFT STATIONS

MULTI-CHANNEL IMPELLER PUMPS

Submersible electric pumps with multichannel open shim impeller. These are ideal to pump clear and turbid water without solid and stringy matter, for example rainwater and treated waste water.

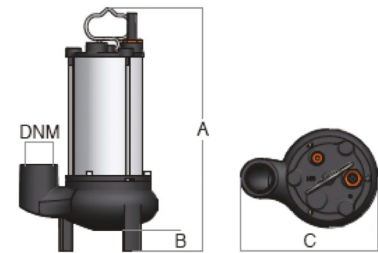

Pump	HP	KW	A	μF	DNM	A mm	B mm	C mm	Weight Kg	Flow rate l/min	Head m
TCN4	1	0,75	4,8	20	1" ½	317	57	188	14,5	35-380	12-1
SM635SL	1,5	1,1	7,3	25	2"	466	60	250	19,3	0-650	15-0

PUMPS WITH VORTEX IMPELLER

Submersible electric pumps with vortex impeller. These are ideal for low head (<8 m) pumping of sewage, including sewage with solid or stringy matter in suspension, such as water from marshy land and untreated domestic sewage

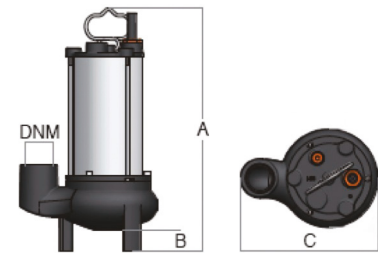

Pump	HP	KW	A	μF	DNM	A mm	B mm	C mm	Weight Kg	Flow rate l/min	Head m
PNRG01	0,4	0,3	2,2	8	1 ¼	263	42	151	9	20-155	6-1
SM265	0,75	0,55	4,2	16	1" ½	400	50	230	16,5	0-300	8,5-1
SM390	1	0,75	5,5	20	2"	450	65	235	18,8	0-500	10,5-1
SM650L	2	1,5	12	31,5	2" ½	445	91	334	22	0-600	9-3
SM590	2	1,5	10,5	31,5	2"	496	162	198	18,2	0-600	15-2
NRG09 (three-phase)	3	2,2	5,3	-	2"	445	184	232	26	0-700	18-2
SM1100/65 (three-phase)	3	2,2	6	-	3"	584	65	417	40	0-900	13-1

PUMPS WITH GRINDER IMPELLER

Submersible electric pumps with grinder impeller. These are ideal for pumping of sewage, including sewage with solid or stringy matter in suspension, such as water from marshy land and untreated domestic sewage. Reduction of the solids into small fragments and the high pressure generated by the pump allow considerable differences in level to be overcome.

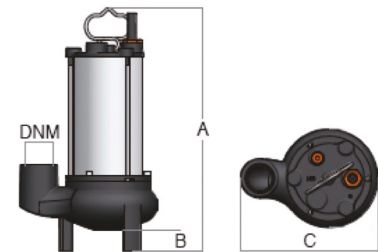

Pompa	HP	KW	A	μF	DNM	A mm	B mm	C mm	Peso Kg	Portata lt/min	Preval mt
SM125GR	1,6	1,18	9,2	35	1" ½	416	29	240	20,5	0-110	30-3
PMST2	1,2	0,9	7,3	30+70	1" ¼	385	78	205	23	35-215	16-4
PMST4	2	1,5	11	40+70	40 mm	442	92	268	38	20-245	22-6
PMST5 (three-phase)	3	2,2	5,3	-	40 mm	442	92	268	40	30-255	28-6

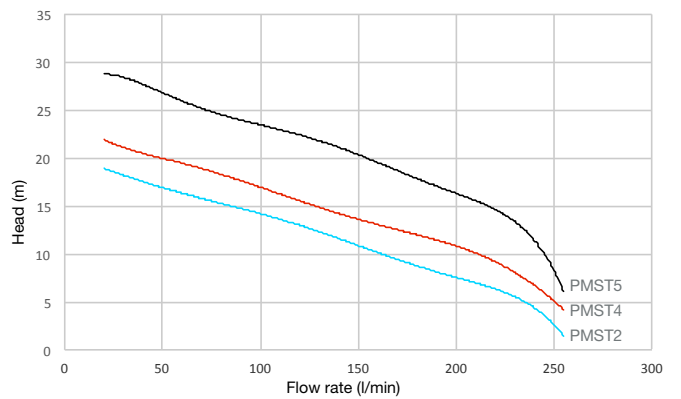
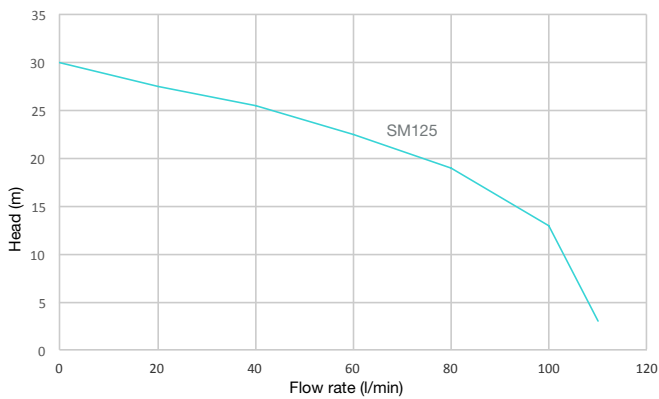
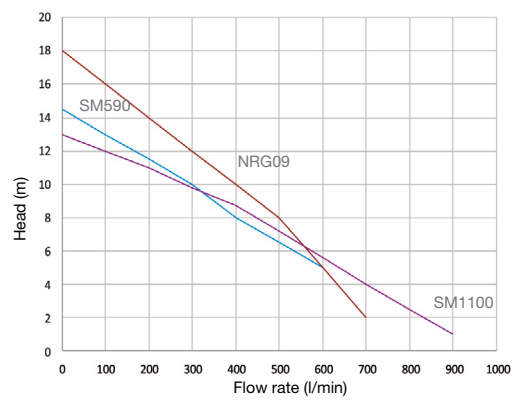
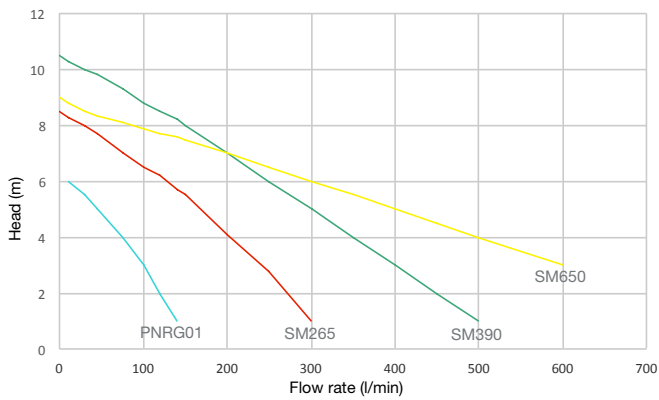
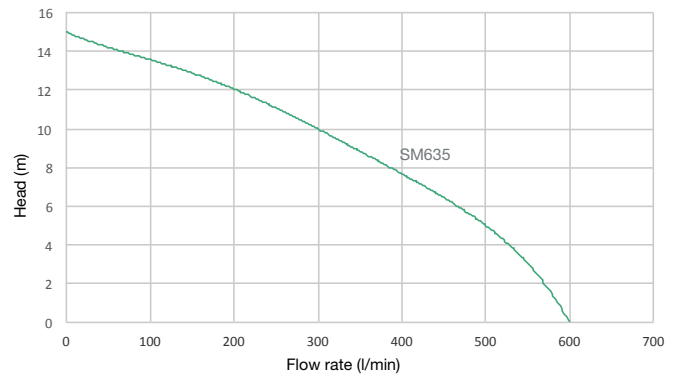
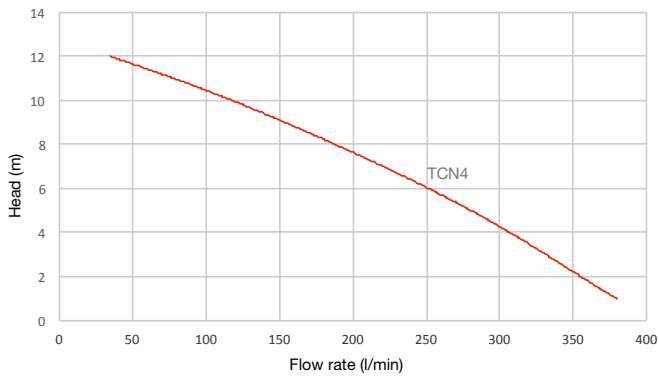

PANELS FOR LIFT STATIONS



DIRECT ELECTRIC PANEL FOR SINGLE PUMP LIFT STATION

Item	Pump power		Current		Size			Weight Kg
	KW	HP	from (A)	to (A)	Height mm	Length mm	Depth mm	
QCSOLP1	0,37-2,2	0,5-3	2	16	340	240	170	1,5
QCSOLP1T	0,55-3,7	0,75-5,5	2	8	340	240	170	2

FUNCTION

pump start-up panel for sewage lift station. The start-up command can be either manual or automatic by means of start/stop float switches in the tank. The electric panel is fitted with visual alarms (warning lights) and is set-up for connecting a self-powered audible alarm (mod. QALARM) to signal faults, including in the presence of a power cut. The power supply can be single-phase (domestic type: 230 V) or three-phase (industrial type: 400 V).



DIRECT ELECTRIC PANEL FOR DUAL PUMP LIFT STATION

Item	Pump power		Current		Size			Weight Kg
	KW	HP	from (A)	to (A)	Height mm	Length mm	Depth mm	
QCSOLP2	0,37-2,2	0,5-3	2	16	340	240	170	4
QCSOLP2T	0,55-3,7	0,75-5,5	2	8	340	240	170	5,5

FUNCTION

pump start-up panel enabling activation of alternate or simultaneous operation mode of n. 2 pumps for sewage lift station. The start-up command can be either manual or automatic by means of a series of start/stop float switches positioned at different levels in the tank. The electric panel is fitted with visual alarms (warning lights) and is set-up for connecting an audible alarm (mod. QALARM) to signal faults. The power supply can be single-phase (domestic type: 230 V) or three-phase (industrial type: 400 V).



ALARM UNIT ELECTRIC PANEL

Item	Power supply V	Float			Weight Kg
		Height mm	Length mm	Depth mm	
QALARM	220	160	160	140	0,5

FUNCTION

audible/visual alarm for fault signalling. The unit is set-up for connecting to the electric start-up panels of sewage pumps and level floats (overflow). For installation in lift stations.

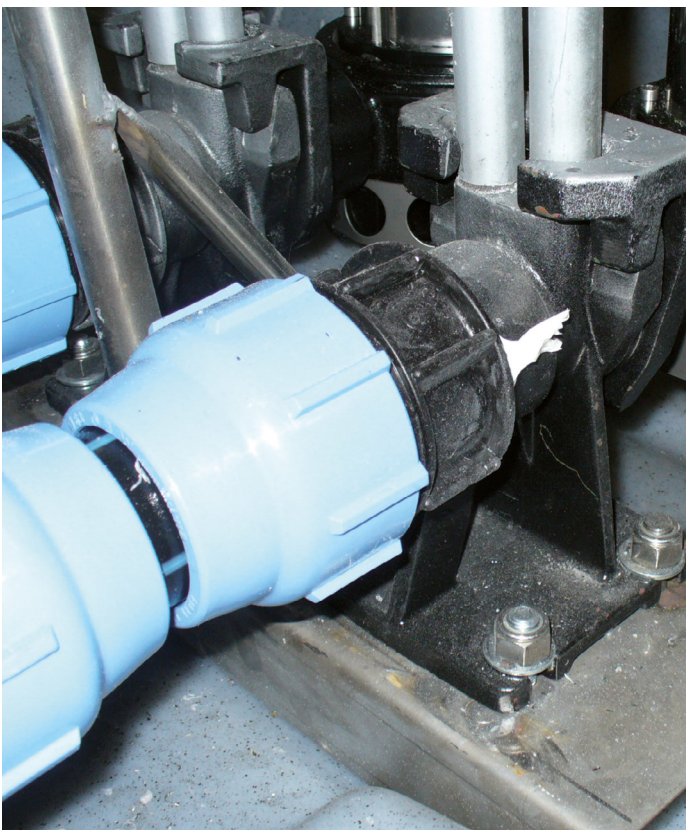

TECHNICAL SECTION - LIFT STATIONS

TECHNICAL CHARACTERISTICS

Sewage lift stations are systems that allow effluent to be lifted and transferred to stations located at higher levels (sewerage systems, treatment systems). They become necessary, for example, when the discharge level of a WC is lower than that of the treatment plant or sewerage pipes (cellars, underground premises, etc.) and when the hydraulic profile of the treatment system cannot work by gravity.

The station consists of a linear polyethylene (LLDPE) storage tank of various sizes, with a **submerged electric pump installed** inside it. The pump is connected to the tank by a chain to facilitate its removal, and the inlet pipe is fitted with a **cast iron ball check-valve**.

If the flow rates of waste water to be lifted are very high and/or variable and if the presence of a spare pump is necessary, **dual pump models** are provided. The pumps are connected to suitable electric panels so that, according to requirements, the start-up command can be either manual or automatic by means of start/stop float switches located inside the tank.

The dual pump models are provided with an **electric panel** allowing alternating or simultaneous operation of the 2 pumps to be activated. The electric panel can also be fitted with visual alarms (warning lights) and is set-up for connecting an audible alarm device. The power supply can be single-phase (domestic type: 230 V) or three-phase (industrial type: 400 V). Depending on need, the lift stations can be equipped with various types of pumps with different heads, flow rates and working pressures. For pumps possessing particular characteristics, contact the ROTOTEC technical office. A **three-phase version** of the electric pumps and electric panels can be supplied on request.

USE AND MAINTENANCE

All maintenance operations must be carried out with the pump disconnected from the power supply. The pump must be disconnected by trained technicians, so that there is no risk of it starting accidentally.

The maintenance recommendations indicated are not to be understood as “do-it-yourself” operations, as they require specific technical knowledge. A service contract with a specialist technician will ensure you receive the best technical assistance at all times.

In order for a lift station to function efficiently, it is important that the **most suitable pump for satisfying the specific requirements** is selected during the design phase. To this end, a few important parameters such as the origin and characteristics of the effluent to treat, the function of the lift station, **the head and linear distance to the receiver** must be evaluated.

Even when the pump is capable of handling solid and stringy matter (**vortex impeller**) it is nevertheless advisable to install a primary sedimentation system (e.g. septic tank) upstream or a sewage screening system that can separate non-shreddable materials such as rags, plastics, etc. The installation of such a system is essential when pumps with **2-channel impeller** are installed.

Under normal operating conditions, the electric pumps do not require any maintenance operations.

MANAGEMENT

WHAT TO DO	WHEN	HOW
Inspect the lifting station	Every 6 months	Unscrew the covers on the inspection holes and check the level of sediments on the bottom
Check the seal on pipes, connectors and gaskets	Every 6 months	Check inlet and outlet pipes
Check vent pipe	Every 6 months	If anything is obstructing the free flow of air, remove it
Check the pumping system	Every 12 months	Extract the pump*, clean the inlet to remove any debris, assess the state of the impeller, the electric cable and the floats
Remove bottom sediment and clean the inlet and outlet pipes	Every 6 / 12 months	Contact a licensed waste disposal company

* To dismantle a pump it is necessary to **unfasten the compression fitting** on the pump delivery pipe, then extract the pump, with the aid of the **lifting chain**.

WARNINGS

- provide for a **vent of a size suited** to the power of the pump, to prevent the formation of a vacuum in the tank;
- Only start the electric pump once it has been installed, **do not attempt a dry start**;
- Do not remove the suction filter, if there is one, for any reason whatsoever;
- Avoid operating the pump in the horizontal position. The pump can only function in the **vertical position** (with the motor at the top and the pump part at the bottom);
- On the **three-phase version**, the correct direction of rotation is indicated by the arrow stamped on the pump body and on the identification plate.
- If the electric pump is not properly fixed, it may become unsteady or topple over on start-up due to the starting torque;
- Never use the electric pump to **pump dangerous liquids** (toxic, flammable, etc...);
- in the event of a maintenance operation of any kind, always comply with the **safety regulations** regarding operations within closed waste water treatment areas, and with the general technical procedures applicable.
- provide for a **vent of a size suited** to the power of the pump, to prevent the formation of a vacuum in the tank;
- Only start the electric pump once it has been installed, **do not attempt a dry start**;
- Do not remove the suction filter, if there is one, for any reason whatsoever;
- Avoid operating the pump in the horizontal position. The pump can only function in the **vertical position** (with the motor at the top and the pump part at the bottom)

RISK OF ELECTRIC SHOCK

- Do not transport or handle the pump using the electric power supply cable.
- Never move the electric pump when it is operating or with the power cable connected to the power supply;
- Before connecting up the pump, make sure that the power supply network is properly earthed;
- Before carrying out any type of control or maintenance operation, disconnect the power supply;
- Never start the pump if you are in contact with the liquid to be pumped;
- Always ensure that the pump is checked and repaired by authorised personnel only. Unauthorised repairs might make the product unsafe and/or dangerous;
- Never put your hands or other objects into the pumped liquid inlets or outlets in the vicinity of the impellers, if present, as these are moving parts;