

# PANETTONE



## Type

Above ground tank

## Applications

Storing foodstuffs - Water, oil, wine

## Volumes

From 500 to 14300 litres

## Installation

Simply placed directly on a flat supporting surface

## Available colours:

standard



blue

on request



grey



green



terracotta

Item	Capacity l	Ø cm	Height cm	Ø cover cm	Cover	Inlet	Outlet	Full drain outlet	Lifting eye	Threaded insert dimensions cm		
										A	B	Int.
<b>P500</b>	538	100	80	21	CS200	¾"	¾"	N.P.	-	5	-	-
<b>P1000</b>	1040	120	105	30	CS300	1"	1"	¾"	3	9	5	11
<b>P2000</b>	2075	150	133	40	CS400	1"	1"	¾"	3	9	5	11
<b>P3000</b>	3105	183	135	40	CS400	1"	1"	¾"	3	10	6	12
<b>P5000</b>	4905	225	135	40	CS400	1"	1½"	1"	3	10	6	12
<b>P7500</b>	7800	225	210	40	CS400	1"	1½"	1"	3	10	6	12
<b>P11000</b>	11150	246	278	63	TAP800	N.P.	N.P.	N.P.	3	-	-	-
<b>P15000</b>	14300	246	355	63	TAP800	N.P.	N.P.	N.P.	3	-	-	-

N.P. Not present.

## THREADED INSERTS IN GALVANISED BRASS

(on request)



See table at pag. 16

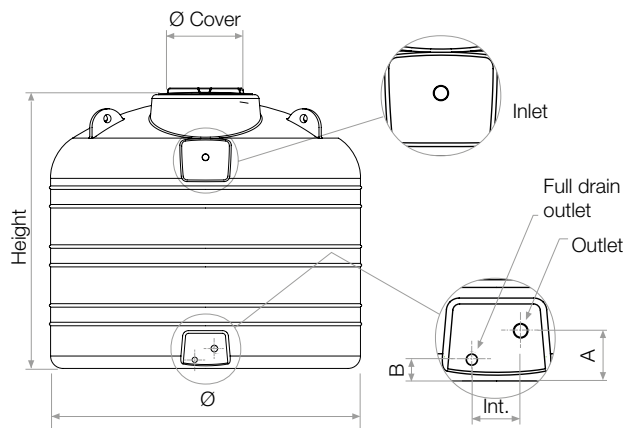
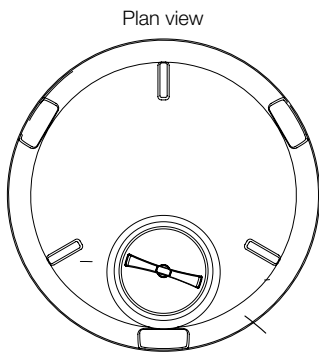

# TECHNICAL SECTION – EXTERNAL TANKS

## TECHNICAL CHARACTERISTICS

Thanks to rotational moulding technology and the chemical-physical-mechanical characteristics of linear polyethylene (LLDPE), the above ground tanks possess the ideal characteristics for the problem-free storage of large volumes of liquids. Polyethylene, in fact, is totally **non-toxic** and does not foster the growth of algae in the fluids contained in the tanks, thus making the tanks ideal for storing potable water and other foodstuffs. Furthermore, linear polyethylene also supports sudden changes in temperature (from -20 to + 80 °C) and is **inert** in the presence of chemical and physical atmospheric agents. For these reasons, there are no material oxidation or corrosion problems that would prejudice the mechanical characteristics and impermeability of the tanks. These characteristics are also guaranteed by the fact that rotational moulding allows **one-piece tanks** to be produced, i.e. free of welds that could weaken parts of the tanks subjected to internal stresses. Furthermore, while possessing the same characteristics as other materials (cement, fibreglass, metal), tanks in polyethylene are much **lighter**, and as such transport, installation and maintenance are extremely simple and economic. Finally, polyethylene tanks **can be bored** when the need arises, for example when connecting tanks together, installing inlet/outlet pipes, overflows, etc. ROTOTEC supplies a wide range of tank models for outdoor use of capacities ranging from 50 to 14300 litres. The various forms of the tanks are designed to create storage facilities even in locations where installation space is restricted (e.g. cellars, attics, stairwells...). Thanks to the **flanged joints or brass/plastic pipe unions** mounted on the appropriate flat areas, the various tanks can be connected together to obtain larger storage volumes. Each tank is equipped with a threaded or hinged **inspection cover**, and many models are fitted with **discharge and full drain outlet holes**. The standard colour of outdoor tanks is blue. Other colours are also available on request, such as Green, Black, Terracotta and Grey. Finally, on request, above ground tanks can also be equipped with the appropriate **pumps** for delivering the stored water at the flow rates, pressures and heads needed for the various applications.

## APPLICATIONS

The characteristics previously mentioned render the outdoor tanks ideal for:

- **Storing potable water or other liquids** in areas either outside or inside residential properties;
- **Creating large volumes of stored water** for fire-fighting, washing or irrigation plants;
- **Creating lift stations** for pumping water to higher levels;
- **Collecting and storing rainwater** for re-use in irrigation or washing

## WARNINGS

In order to ensure that the characteristics of the tanks remain unaltered over time, that the stored substances do not deteriorate and that the ROTOTEC guarantee remains valid (25 years against full-depth corrosion) the following instructions must be carefully followed:

- **The above ground tanks must not, under any circumstances, be installed underground;**
- **Prior to installation, carefully check the integrity of the tanks** and the tightness of the gaskets;
- Do not install the tanks near to sources of heat;
- **The tanks must be positioned on a flat, stable surface;**
- When installing the tanks, to prevent the formation of algae, make sure that no light can filter in;
- Use flexible hoses when connecting to the water system in order to prevent stresses during tank filling and emptying;
- Do not leave the tank without its cover for any length of time;
- In the case of rainwater storage, it is advisable to install a filter chamber upstream of the tank to prevent a build-up of grit, silt, leaves, etc. inside the tank;
- **For storing fluids not expressly indicated in this catalogue (page 262), contact the technical office;**
- Place the tanks in easily reachable locations and avoid constructing parts in brickwork that could interfere with replacement or maintenance operations;
- When installing a pump, internally or externally, fit a suitable sized vent on the tank to prevent the formation of a vacuum when the pump is running.

## USE AND MAINTENANCE

- When carrying out maintenance operations and cleaning of the tank and any components installed inside it, always comply with the requirements indicated in the safety regulations about temporary or mobile work sites;
- **keep the area around the tank free** from any material that might obstruct or impede the maintenance work;
- always work in pairs when carrying out tank inspection and cleaning operations, and wear suitable safety equipment;
- **check the tank every 6 months**. If any sediment is found on the floor, extract it and clean the tank carefully using a normal domestic detergent. If any foreign bodies are found, disinfect the tank thoroughly;
- **check that any PVC inlet, outlet, overflow pipes or brass or plastic filling, drainage, full drain connectors are not blocked** by large solids that prevent the passage of the fluid in the tank. If any sediment is found, it must be removed;
- **check every 6 months** to ensure that pipes, connectors and gaskets are sealed;
- **periodically check that the vent serving the pump and installed on the tank is free**. If it is blocked it must be cleaned.